



**350 MM  
MAX**

**MAXIMUM  
HEIGHT**



**2000 KG  
MAX**

**MAXIMUM  
RATED LOAD**

**2000 KG**  
**HYDRAULIC JACK**  
*USER GUIDE*

**FUNCTIONS**

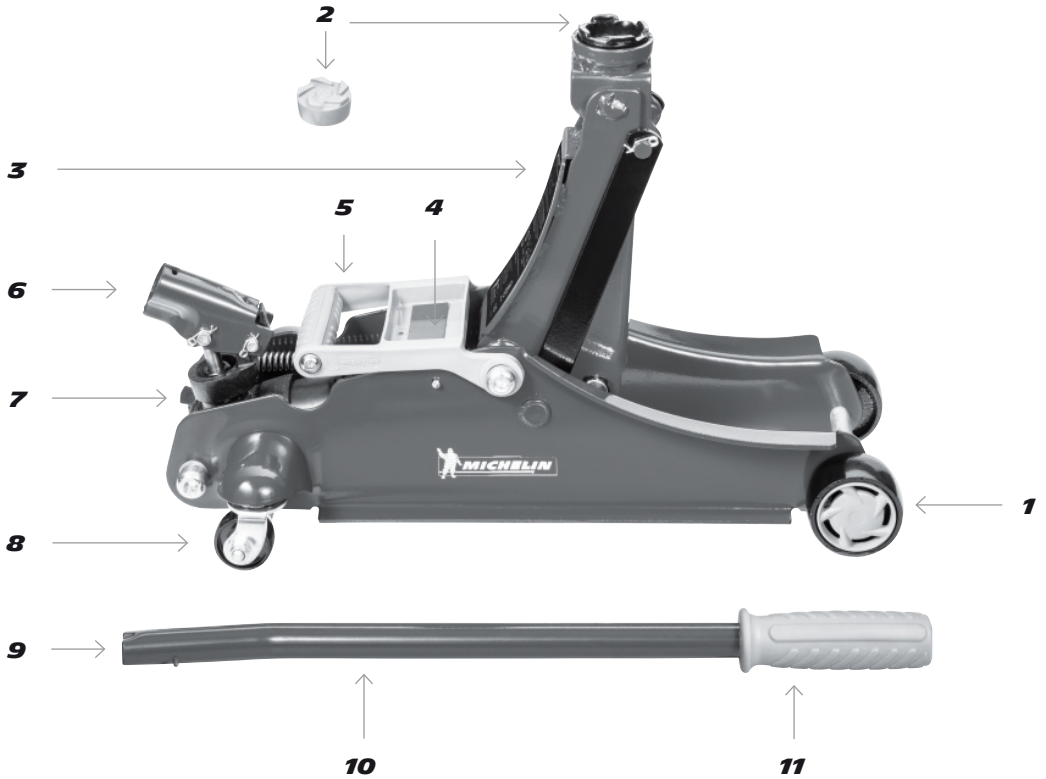

- 1. Front wheel
- 2. Soft grip saddle
- 3. Lifting arm
- 4. Magnetic tool tray for wheel nuts
- 5. Carry handle
- 6. Handle sleeve
- 7. Release valve
- 8. Rear castor
- 9. Engage release valve with this end
- 10. Handle
- 11. Handle grip

# **2000 KG HYDRAULIC JACK**

## **USER GUIDE**

**SAVE THESE INSTRUCTIONS!** For your safety, read, understand, and follow the information provided with and on this jack. Car jack owners and users must be thoroughly familiar with the safety procedures for car jack use before using it for the first time. The owner and operator must be aware that use and repair of this product may require special skills and knowledge. Instructions and safety information shall be conveyed in the operator's native language before use of this jack is authorized. If any doubt exists as to the safe and proper use of this jack, remove from service immediately.

**Inspect before each use.** Do not use if broken, bent, cracked, if certain parts are damaged or rusted (including nameplates) or oil is leaking. Any jack that appears damaged in any way, operates abnormally or is missing parts, shall be removed from service immediately. If the jack has been, or suspected to have been, subjected to a shock load (a load dropped suddenly, unexpectedly upon it), immediately discontinue use and remove from service. If a malfunction occurs during use (seized lifting rod, plunger stuck), contact a professional or customer service.

In the event of an oil leak, discontinue use. Ensure no further oil leaks and immediately absorb the oil which has leaked and dispose through designated facilities. **It is recommended that an annual inspection be done by qualified personnel.**

### **PRODUCT DESCRIPTION / SAFETY INSTRUCTIONS**

This MICHELIN 2000 kg Hydraulic Jack is designed to lift, but not sustain, rated capacity loads. It is designed to be used in conjunction with jack stands. The MICHELIN 2000 kg Hydraulic Jack has a unique feature which provides fast, no load lifts to the jacking point.

**Intended use:** To lift one axle of a vehicle for the purpose of service and / or repair of vehicle components. After lifting, loads must be immediately supported by appropriately rated jack stands. Check with vehicle owner's manual for proper jacking points.

### **BEFORE USE**

1. Verify that the product and the application are compatible, if in doubt call the Customer Support: +49 (0) 7131 27588-44.
2. Before using this product, read the owners manual completely and familiarize yourself thoroughly with the product, its components and recognize the hazards associated with its use.
3. Check to ensure that the jack rolls freely and that the pump operates smoothly before putting into service.

## ***SPECIFICATIONS***

Maximum rated load:	2,000 kg
Minimum height:	105 mm
Maximum height:	350 mm
Hoisting:	245 mm
Operating temperature:	-20 °C to +50 °C

## ***WARNING & SAFETY INFORMATION!***

Study, understand, and follow all instructions provided with and on this device. Do not exceed rated capacity. This is a lifting device only. After lifting, immediately transfer the load to appropriately rated jack stands. Never work on, under, or around a load supported by this device. Use only on hard, level surfaces capable of supporting the load marked on the equipment. Do not move or dolly loads with this device. Failure to heed this warning may result in personal injury and / or property damage.

- Never use the car jack to lift persons. Do not use the car jack with people inside or leaning against the vehicle.
- The user must keep an eye on the jack and the load during all movement.
- The condition of the markings on the car jack must be checked regularly and the markings must always correspond with the original markings.

### **Do not use the car jack in the following situations:**

- Outdoors in frost / rain.
- In severe conditions (e.g. very cold or very hot weather, when exposed to strong magnetic radiation and similar situations).
- In potentially explosive environments, mines and similar situations.
- When lifting loads containing the following materials, among others: molten metal, acid, radioactive material or loose / not firmly connected goods and similar situations.
- In contact with food and similar situations.
- On ships and in similar situations.

To avoid any risk of being crushed or sustaining other injuries: NEVER work on, under or around a load supported only by a jack. ALWAYS use adequately rated jack stands. If the generated efforts exceed 400 N (approx. 40 kg), the effort shall be lowered by additional person.

Be sure all tools and personnel are clear before lowering load. Do not alter or modify the car jack which will adversely affect the car jack's compliance with standard EN 1494:2000+A1:2008. Only attachments and / or adaptors supplied by the manufacturer shall be used. Only lift the vehicle using the jacking points specified by the vehicle manufacturer.



Handbreak on

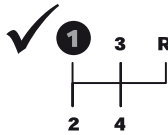

Leave car in gear

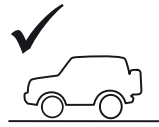

Use on a flat surface

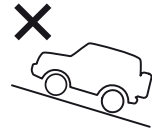

## **OPERATION**

### **LIFTING VEHICLE**

1. Place vehicle in park, with emergency brake on and wheels securely chocked to prevent inadvertent vehicle movement.
2. Locate and close release valve by turning handle clockwise until firm resistance is felt to further thread engagement. Center jack saddle under lift point.
3. Verify lift point, insert handle into handle sleeve and pump to contact lift point. To lift, pump handle until load reaches desired height.
4. Transfer the load immediately to appropriately rated jack stands.

### **LOWERING VEHICLE**

1. Raise load high enough to clear the jack stands, then carefully remove jack stands (always used in pairs).
2. Slowly turn the handle anti-clockwise, but no more than a 1/2 full turn.
3. After removing jack from under the load, push soft grip saddle down to lower lifting arm as much as possible.

## ***MAINTENANCE***

- Check the car jack for damage, oil leaks and corrosion before every use. Do not use the car jack if damaged. Only use original manufacturer parts. Maintenance and repairs must always be performed by qualified professionals. Have the oil level regularly checked by a speciality shop.
- Clean the car jack with a dry rag or cloth. Do not use chemical, alkaline, abrasive or other aggressive cleaners, as these will harm the surfaces.
- Keep the grips free from oil to prevent accidental slipping and the injuries this will cause.
- Regularly lubricate moving car jack parts (e.g. with spray lubricant).
- Check the car jack for signs of corrosion and rust. Clean the affected areas with a cloth dipped in oil.
- **IMPORTANT:** Always store the car jack in the lowered position!

## ***DISPOSAL***

When disposing of this device, please contact your local retailer or a local recycling centre. Never dispose of the device in regular household waste! This will greatly contribute to protecting the environment. Hydraulic oil and objects contaminated with oil (e.g. cleaning cloths) must be disposed through a hazardous waste collection site.

## TROUBLE SHOOTING

Symptom	Possible Causes	Corrective Action
Jack will not lift load	<ul style="list-style-type: none"> <li>• Release valve not tightly closed</li> <li>• Overload condition</li> </ul>	<ul style="list-style-type: none"> <li>• Ensure release valve is tightly closed</li> <li>• Remedy overload condition</li> </ul>
Jack bleeds off after lift	<ul style="list-style-type: none"> <li>• Release valve not tightly closed</li> <li>• Overload condition</li> <li>• Hydraulic unit malfunction</li> </ul>	<ul style="list-style-type: none"> <li>• Ensure release valve is tightly closed</li> <li>• Remedy overload condition</li> <li>• Contact Customer Support</li> </ul>
Jack will not lower after unloading	<ul style="list-style-type: none"> <li>• Linkages binding</li> </ul>	<ul style="list-style-type: none"> <li>• Clean and lubricate moving parts</li> </ul>
Poor lift performance	<ul style="list-style-type: none"> <li>• Fluid level low</li> <li>• Air trapped in system</li> </ul>	<ul style="list-style-type: none"> <li>• Ensure proper fluid level to be checked by specialist</li> </ul>
Will not lift to full extension	<ul style="list-style-type: none"> <li>• Fluid level low</li> </ul>	<ul style="list-style-type: none"> <li>• Ensure proper fluid level</li> </ul>



**Customer enquiries:**

We're at your service. Let us help you find a better way forward.

**Tel: +49 (0) 7131 27588-44**  
**Michelin@helix-automotive.com**

Manufactured and distributed under licence by  
 Helix Automotive GmbH, Fischeracker 4, DE-74223 Flein

© 2021 Michelin, [www.michelin-lifestyle.com](http://www.michelin-lifestyle.com)

MICHELIN and/or the Michelin Man Device and/or BIBENDUM are trademark(s) owned by, and used with the permission of, the Michelin Group.

